



**Bobcat**®

## Tiller Attachment



***One Tough Animal***™

## Specifications

Tiller	38 inch	62 inch	76 inch
Working Width:	38 in. (966 mm)	62 in. (1575 mm)	75.5 in. (1918 mm)
Overall Width:	48 in. (1220 mm)	71 in. (1803 mm)	84.5 in. (2146 mm)
Tines:	32	36	44
Max. Working Depth:	4 in. (102 mm)	6 in. (152 mm)	6 in. (152 mm)
Tine Rotation:	Bi-rotational	Bi-rotational	Bi-rotational
Drive:	Hydraulic with end-drive oil-bath chain	Direct	Direct
Travel Direction:	Forward/Reverse	Forward/Reverse	Forward/Reverse
Weight:	575 lb. (261 kg)	684 lb. (310 kg)	773 lb. (351 kg)
Flow Range:	9-18 gpm (34-68 L/min.)	17-37 gpm (64-140 L/min.)	17-37 gpm (64-140 L/min.)



62 in. and 76 in. Tillers have manual depth adjustments of 2, 4 and 6-inch depths

Dimensions	A	B
38 in. Tiller	38 in. (966 mm)	48 in. (1220 mm)
62 in. Tiller	62 in. (1575 mm)	70.8 in. (1803 mm)
76 in. Tiller	75.5 in. (1918 mm)	84.4 in. (2146 mm)

### Till and mix for seedbed or sodbed preparation

It's easy to break new ground with the Bobcat tiller attachment. It can quickly turn a backyard plot into a garden, break up clumps, and mix compost and other materials into the soil.

- Working widths of 38, 62 or 76 inches.
- Bi-directional rotation allows both top-cutting and under-cutting in either travel direction.
- Offset mounting permits tilling next to sidewalks, curbs and buildings.
- Hydraulically-powered; no shear pins to maintain.
- Able to use high-flow hydraulics for enhanced performance.
- Hardened, double-edge, replaceable tines.
- Exclusive Bob-Tach™ mounting system permits quick hook-up to loader.
- Backed by Bobcat warranty and worldwide parts and service support.

NOTE - Where applicable, dimensions are in accordance with Society of Automotive Engineers (SAE) and ISO standards. Specifications and design are subject to change without notice. Pictures of Bobcat units may show other than standard equipment. All dimensions are given for loader equipped with standard tires. All dimensions are shown in inches. Respective metric dimensions are enclosed by parentheses. Bobcat Company complies with the requirements of ISO 9001 as registered with BSI.

*The Bobcat Attachments Advantage: Bobcat attachments are engineered and manufactured to fit Bobcat loaders for optimum job performance, dependability and durability.*

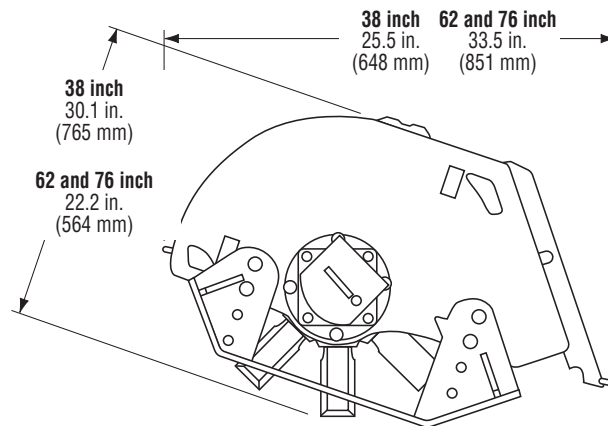
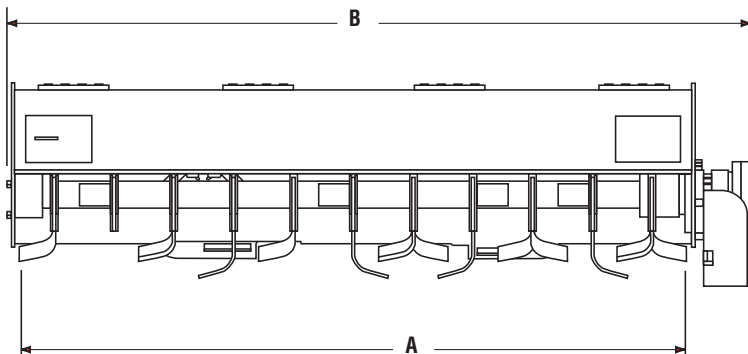

**Bobcat Tiller Attachment fits these carrier models:**

**Mini Track Loaders:**  
MT52  
MT55

**Skid-Steer Loaders:**  
463  
553  
S70  
S100  
S130  
S150  
S160  
S160H  
S175  
S185  
S185H  
S205  
S205H  
S220  
S220H  
S250  
S250H  
S300  
S300H  
S330  
S330H

**Compact Track Loaders:**  
T140  
T180  
T180H  
T190  
T190H  
T250  
T250H  
T300  
T300H  
T320  
T320H

**All-Wheel Steer Loaders:**  
A300  
A300H

**Utility Work Machine:**  
5600  
5610

**Telescopic Tool Carriers:**  
V417