



**Bobcat**®

## Pallet Fork Attachment



***One Tough Animal***™

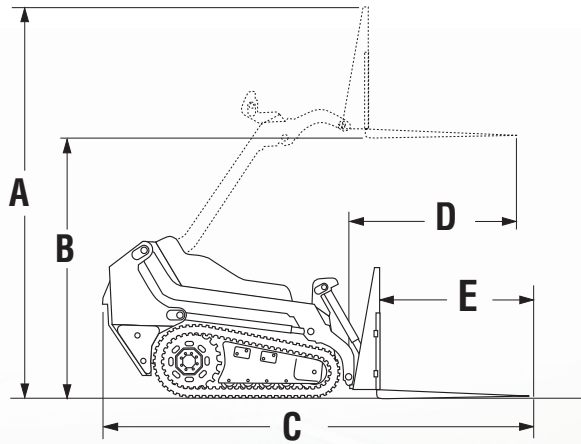
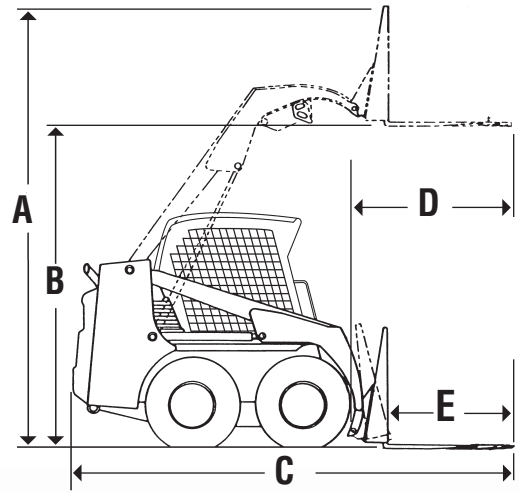
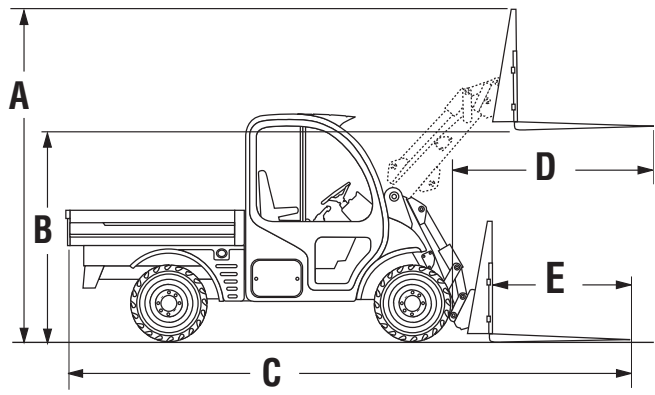

## Specifications

### PALLET FORK SPECIFICATIONS

Frame	Frame Width	Frame Height	Frame Weight	Tooth Length	Tooth Wt. (set of 2)	Total Weight
<b>Small</b>	37 in.	34.5 in.	105 lb.	30 in. 36 in.	130 lb. 147 lb.	235 lb. 252 lb.
<b>Standard</b>	46 in.	39 in.	200 lb.	30 in. 36 in. 42 in. 48 in.	130 lb. 147 lb. 164 lb. 181 lb.	330 lb. 347 lb. 364 lb. 381 lb.
<b>Heavy-Duty</b>	60 in.	49 in.	470 lb.	42 in. 48 in.	214 lb. 238 lb.	684 lb. 708 lb.

### SMALL PALLET FORK (with 36 in. teeth)

Loader Size	A	B	C	D	E
<b>MT52</b>	101 in.	66 in.	110 in.	45 in.	36 in.
<b>MT55</b>	101 in.	66 in.	113 in.	51 in.	36 in.
<b>463/S70</b>	124 in.	90 in.	120 in.	40 in.	36 in.

### HEAVY-DUTY PALLET FORK (with 48 in. teeth)

Loader Size	A	B	C	D	E
<b>S220</b>	167 in.	117 in.	169 in.	70 in.	48 in.
<b>S250*</b>	173 in.	123 in.	169 in.	78 in.	48 in.
<b>S300*</b>	171 in.	123 in.	172 in.	78 in.	48 in.
<b>S330</b>	171 in.	123 in.	172 in.	77 in.	48 in.
<b>A300*</b>	171 in.	123 in.	172 in.	78 in.	48 in.
<b>T250</b>	166 in.	117 in.	169 in.	70 in.	48 in.
<b>T300/T320*</b>	173 in.	123 in.	169 in.	78 in.	48 in.

### PALLET FORK RATINGS (Small)

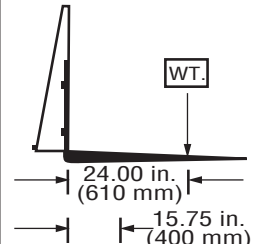
	Loader Rated Operating Capacity		Pallet Fork Load Rating at 15.75 in.	
	500 lb. (230 kg)	260 lb. (120 kg)		
	600 lb. (270 kg)	350 lb. (160 kg)		
	700 lb. (320 kg)	440 lb. (200 kg)		

### PALLET FORK RATINGS (Standard)

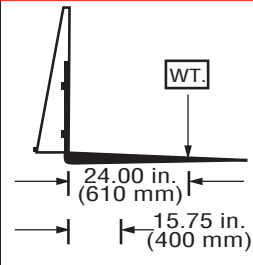
	Loader Rated Operating Capacity		Pallet Fork Load Rating at 24 in.	
	950 lb. (430 kg)	410 lb. (190 kg)		
	1200 lb. (540 kg)	660 lb. (300 kg)		
	1300 lb. (590 kg)	770 lb. (350 kg)		
	1500 lb. (680 kg)	950 lb. (430 kg)		
	1700 lb. (770 kg)	1120 lb. (510 kg)		
	1900 lb. (860 kg)	1270 lb. (580 kg)		
	2100 lb. (950 kg)	1380 lb. (630 kg)		
	2300 lb. (1040 kg)	1500 lb. (680 kg)		
	2500 lb. (1130 kg)	1560 lb. (710 kg)		

### PALLET FORK RATINGS (Heavy Duty)

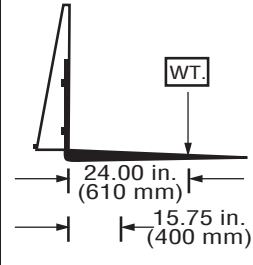
	Loader Rated Operating Capacity		Pallet Fork Load Rating at 24 in.	
	2000 lb. (910 kg)	1300 lb. (590 kg)		
	2200 lb. (1000 kg)	1430 lb. (650 kg)		
	2400 lb. (1090 kg)	1560 lb. (710 kg)		
	2600 lb. (1180 kg)	1690 lb. (770 kg)		
	2800 lb. (1270 kg)	1820 lb. (830 kg)		
	3000 lb. (1360 kg)	1950 lb. (880 kg)		
	3200 lb. (1450 kg)	2080 lb. (940 kg)		
	3400 lb. (1540 kg)	2210 lb. (1000 kg)		
	3600 lb. (1630 kg)	2340 lb. (1060 kg)		

### STANDARD PALLET FORK (with 48 in. teeth)

Loader Size	A	B	C	D	E
<b>S100/T110</b>	137 in.	98 in.	144 in.	58 in.	48 in.
<b>S130</b>	142 in.	103 in.	150 in.	61 in.	48 in.
<b>S150/S160</b>	148 in.	109 in.	156 in.	57 in.	48 in.
<b>S175/S185</b>	151 in.	113 in.	156 in.	67 in.	48 in.
<b>S205</b>	151 in.	112 in.	156 in.	68 in.	48 in.
<b>S220</b>	156 in.	116 in.	169 in.	62 in.	48 in.
<b>S250*</b>	156 in.	123 in.	169 in.	70 in.	48 in.
<b>T140</b>	143 in.	104 in.	150 in.	61 in.	48 in.
<b>T180</b>	151 in.	109 in.	156 in.	57 in.	48 in.
<b>T190</b>	151 in.	112 in.	158 in.	68 in.	48 in.
<b>5600-C</b>	117 in.	77 in.	202 in.	79 in.	48 in.
<b>5600-D</b>	117 in.	79 in.	202 in.	78 in.	48 in.

\*Dimensions A and B will be 2 inches less on machines older than K-series



## Specifications

### HYDRAULIC PALLET FORK RATINGS

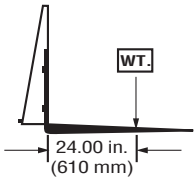

Loader Rated Operating Capacity		
<b>900 lb.</b>	360 lb.	(160 kg)
<b>1300 lb.</b>	550 lb.	(250 kg)
<b>1500 lb.</b>	655 lb.	(295 kg)
<b>1700 lb.</b>	845 lb.	(380 kg)
<b>1900 lb.</b>	990 lb.	(450 kg)
<b>2100 lb.</b>	1050 lb.	(475 kg)
<b>2300 lb.</b>	1150 lb.	(520 kg)
<b>2500 lb.</b>	1250 lb.	(565 kg)
<b>2700 lb.</b>	1350 lb.	(610 kg)
<b>3000 lb.</b>	1680 lb.	(760 kg)

- Adjust fork spacing with fingertip controls inside the cab
- Two hydraulic cylinders adjust outside spacing width from 40.25 in. to 12 in.
- Two sizes of forks to choose from: 42 in. and 48 in.

NOTE - Where applicable, dimensions are in accordance with Society of Automotive Engineers (SAE) and ISO standards. Specifications and design are subject to change without notice. Pictures of Bobcat units may show other than standard equipment. All dimensions are given for loader equipped with standard tires. All dimensions are shown in inches. Respective metric dimensions are enclosed by parentheses. Bobcat Company complies with the requirements of ISO 9001 as registered with BSI.

*The Bobcat Attachments Advantage: Bobcat attachments are engineered and manufactured to fit Bobcat loaders for optimum job performance, dependability and durability.*

### HYDRAULIC PALLET FORK SPECIFICATIONS

Frame	Frame Width	Frame Height	Frame Weight	Tooth Lengths	Tooth Wt. (set of 2)	Total Weight
Hydraulic	48 in.	39 in.	383 lb.	42 in. 48 in.	164 lb. 181 lb.	547 lb. 564 lb.



**Bobcat Pallet Fork Attachment fits these carrier models:**

**Mini Track Loaders:**  
MT52  
MT55

**Skid-Steer Loaders:**  
463  
S70  
S100  
S130  
S150  
S160  
S175  
S185  
S205  
S220  
S250  
S300  
S330

**Compact Track Loaders:**  
T110  
T140  
T180  
T190  
T250  
T300  
T320

**All-Wheel Steer Loaders:**  
A300

**Utility Work Machine:**  
5600  
5610

**Bobcat Hydraulic Pallet Fork Attachment fits these carrier models:**

**Skid-Steer Loaders:**  
S130  
S150  
S160  
S175  
S185  
S205  
S220  
S250  
S300  
S330

**Compact Track Loaders:**  
T140  
T180  
T190  
T250  
T300  
T320

**All-Wheel Steer Loaders:**  
A300

**Utility Work Machine:**  
5600  
5610

**Check out similar attachments:**  
Utility Fork



# Bobcat®

Visit [bobcat.com/anyjob](http://bobcat.com/anyjob) for more information

Bobcat Company • P.O. Box 6000 • West Fargo, ND 58078