



Bobcat®

Mixing Bucket

Attachments



Main features

- Dual discharge.
- Mix and dump functions are fingertip controlled.
- Mix while driving.

Applications

- Construction

| | Item number | Compatible with loader | Compatible with telescopic |
|----------------------------|-------------|--|--|
| Mixing bucket MB250 CD | 6716412 | S175, S185, S205, S220, S250, S300, S330, A300, T140, T190, T250, T300, T320 | – |
| Mixing bucket MB250 SD | 7157681 | S175, S185, S205, S220, S250, S300, S330, A300, T140, T190, T250, T300, T320 | – |
| Mixing bucket 600L for TLS | 6911467 | – | T2556, T2566, T3571, T3571L, T35120SL, T35120L, T40140, T40170 |

Weights and dimensions

| | Operating weight (kg) | Shipping weight (kg) | Overall width (C) (mm) | Overall height (B) (mm) | Overall length (A) (mm) |
|----------------------------|-----------------------|----------------------|------------------------|-------------------------|-------------------------|
| Mixing bucket MB250 CD | 320 | 320 | 1450 | 800 | 760 |
| Mixing bucket MB250 SD | 380 | 410 | 1524 | 917 | 769 |
| Mixing bucket 600L for TLS | 670 | 670 | 1900 | 1070 | 1100 |

Characteristics and performance

| | Capacity (l) | Flow range (l/min) |
|----------------------------|--------------|--------------------|
| Mixing bucket MB250 CD | 250 | – |
| Mixing bucket MB250 SD | 250 | 40 – 90 |
| Mixing bucket 600L for TLS | 600 | 90 – 110 |

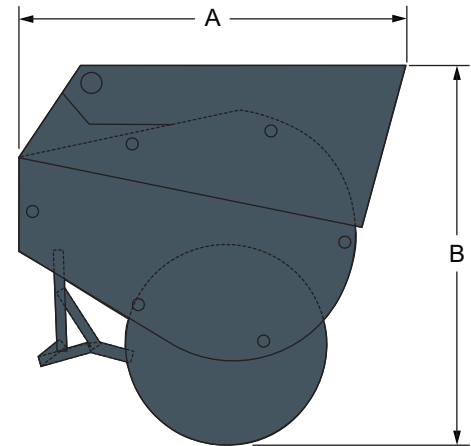
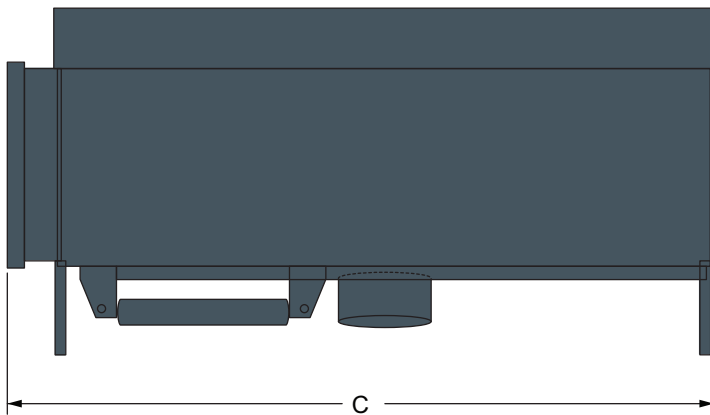

www.bobcat.eu